

正式图 参考图

Mark	ECN NO.	DESCRIPTION	DESIGN	Date:
—	—	NEW VERSION	Peter Wang	2018.09.29

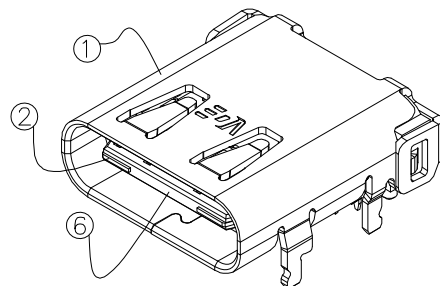

3D VIEW

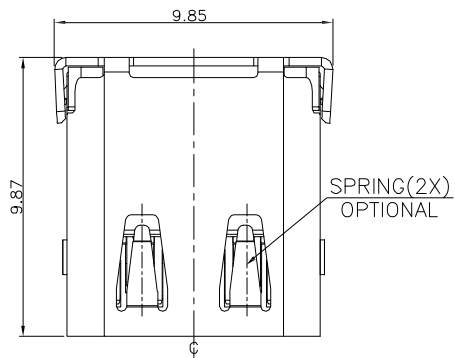
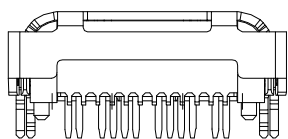
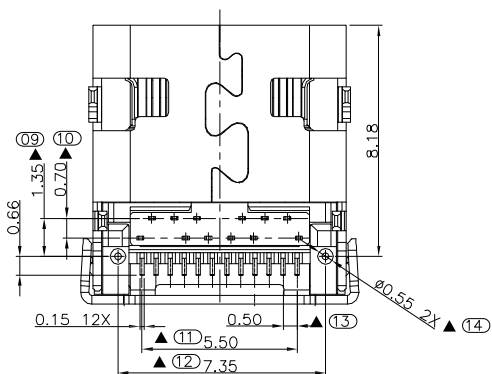
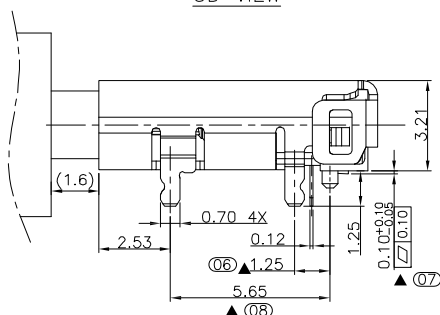
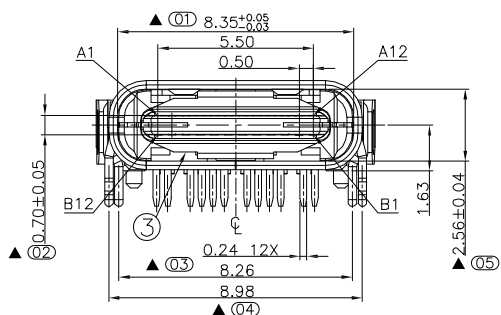
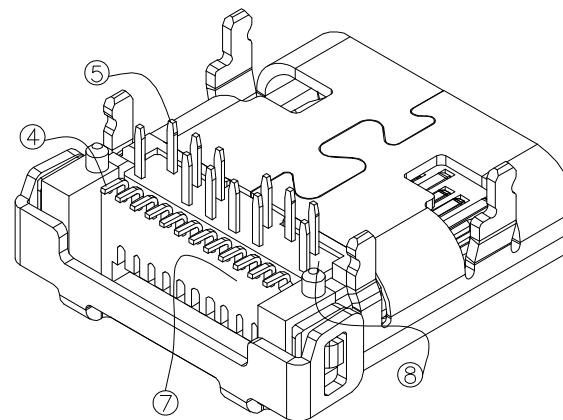

BACK VIEW

P/N:

UB1211W-XXXX-XXXXXXXX

- Model P/N
- Plastic Material (Choose From Table A)
- Housing Color
  - 01:Black.
- Typ
  - 30:USB 3.0
- Product salt mist
  - A:Normal(8 Hours);
  - B:24Hours.
- Packing
  - R:Tape reel.
- Shell Plating Code
  - 1:Ni Plated;
  - 2:G/F With Ni Under Plated.
- Shell Material
  - S:SUS.
- Plating Code
  - L:CONTACT AREA: Au1", SOLDER AEAR: G/F;
  - M: CONTACT AREA: Au15", SOLDER AEAR: G/F;
  - N: CONTACT AREA: Au30", SOLDER AEAR: G/F;

8	DIP Housing	1	See Table A	Black	X
7	SMT Housing	1	See Table A	Black	X
6	Latch Housing	1	See Table A	Black	X
5	DIP Conector	12	Copper Alloy	See P/N	X
4	SMT Conector	12	Copper Alloy	See P/N	X
3	EMI	1	Stainless Steel	—	X
2	Latch	1	Stainless Steel	—	X
1	Shell	1	Stainless Steel	See P/N	X
NO.	DESCRIPTION	QTY	PARTS MATERIAL	PLATING OR COLOR	REMARK

Tolerance
X.X ±0.30
X.XX ±0.20
X.XXX ±0.10
Angle ±3.0°

MODEL NAME:USB 3.0 90度 C TYPE	REVISION	SHEET
MODEL No: UB1211W-XXXX-XXXXXXXX	A0	1/2
SCALE:1:1		

DRAWING: Peter Wang
CHECKED: David Zhou
APPROVED: Jacky Lee
DATE: 2018.09.29

UNIT:mm



菱揚精密有限公司  
Ling Yang Precision Co.,Ltd

FILE: CD/LINGYANG  
DWG NO.UB1211W-A001

Mark	ECN NO.	DESCRIPTION	DESIGN	Date:
—	—	NEW VERSION	Peter Wang	2018.09.29

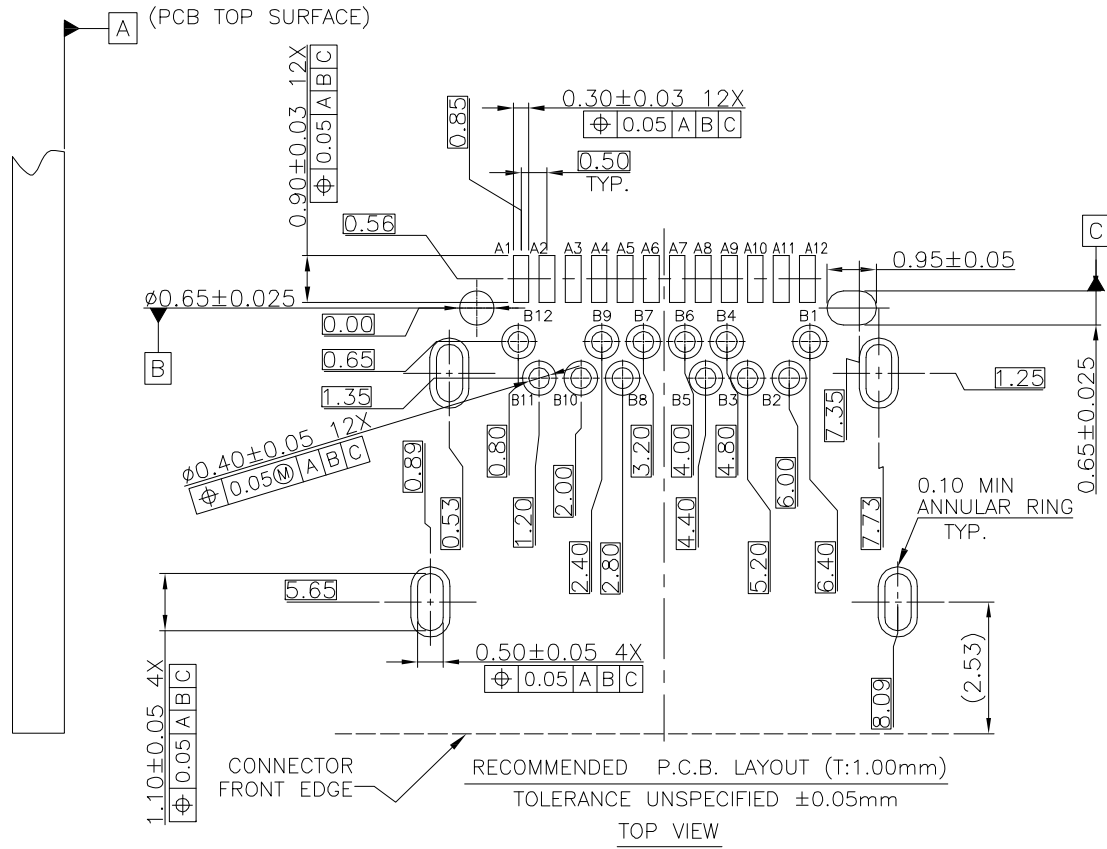

- SPECIFICATIONS:
- MECHANICAL :
    - INSERTION FORCE :5N~20N
    - WITHDRAWAL FORCE :8N~20N  
AFTER 10,000 CYCLES MATING: 6N~20N.
  - ELECTRICAL :
    - Applied current (requirement)
      - 1.1.VBUS PIN;5A
      - 1.2.GND PIN;6.25A
      - 1.3.VCONN PIN;1.25A
      - 1.4.Other contacts;0.25A
    - WITHSTANDING VOLTAGE: 100 VAC FOR 1 MINUTE.  
INSULATION RESISTANCE: 100 MEGOHM MIN.
    - CONTACT RESISTANCE:
      - INITIAL: 40 MILLIOHMS MAX.
      - AFTER TEST: 50 MILLIOHMS MAX.
  - ENVIRONMENTAL :
    - OPERATING TEMPERATURE:-25°C TO +85°C
- 4.SIGN"▲"IS IMPORTANCE DIMENSION.

NO.	CODE	MATERIAL	REMARK
2	C1	LCP UL94V-0	RoHS2 Fit
1	CO	LCP UL94V-0	RoHS2&H.F Fit

TABLE A : Plactical Material

Tolerance X.X ±0.30 X.XX ±0.20 X.XXX ±0.10 Angle ±3.0°	MODEL NAME:USB 3.0 90度 C TYPE		DRAWING: Peter Wang	
	MODEL No: UB1211W-XXXX-XXXXXXX		CHECKED: David Zhou	
UNIT:mm	SCALE:1:1	REVISION	SHEET	APPROVED: Jacky Lee
		A0	2/2	DATE: 2018.09.29
菱揚精密有限公司 Ling Yang Precision Co.,Ltd			FILE: CD/LINGYANG	
			DWG NO.UB1211W-A001	